

KT-5194 DC Motor PID Speed Controller



- Serial, Button or Analog Control
- Open Loop PWM Speed Control
- PID Closed Loop Control
- 16x2 Alphanumeric LCD
- Photo-Interrupter Drive
- Dual IRFZ44 MOSFET Output
- Schmitt Trigger Pulse Input
- Four Unique Addresses

The DC Motor PID Speed Controller is a DC motor speed controller for motors up to 20A. It features open loop PWM control and closed loop PID control. Closed loop control is achieved with the included Photo-Interrupter to provide a pulse input for rotation. All settings for the motor speed controller can be altered using the simple 3 button interface and LCD or via the serial port of a PC, using the supplied program.

Connections:

V+	- Motor Positive input Voltage
M+	- Motor Positive
M-	- Motor Negative
V-	- Motor Negative input Voltage
Vs	- 12V Controller Power Supply Input
COM	- Common Power Supply Connection
OUT	- Photo-Interrupter Drive Output
IN	- Photo-Interrupter Signal Input
5V	- 5V Output for Analog input
AIN	- 0-5V Analog input
COM	- Common (Ground)

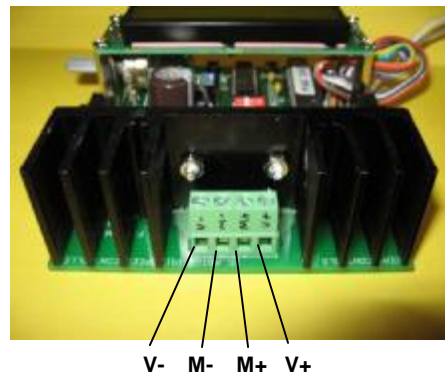

Note: Motor Power Supply must be connected to the V- and V+ terminals. If you are using separate power supplies then their negative terminals must be connected to a common ground for the motor controller to work properly.

Serial Connections:

The motor controller's settings can be altered using its serial port. Each motor controller can have one of four addresses, thus allowing for up to four controllers on a single serial port.

Controller addressing is achieved using the 2-way DIP switch. The address is the sum of the numbers on the switch which are turned on, hence addresses are 0, 1, 2 and 3.

The motor controller features two D9 connectors. Using straight through Male to Female 9-pin serial cables, multiple controllers can be attached to the same serial port without the need to make custom cables.

Menu Structure:

All screens display the speed that the motor is running at on the top line.

The lower line displays the options for setting the speed and other controller settings.

The different screens are selected by using the buttons labeled "<" and ">", and settings can be altered by using the "E" (Enter) button.

When the "E" button is pressed the value being altered will return to its lowest possible value and a cursor will appear under the last character of the editable value.

When the cursor is present, pushing the ">" button will increase numerical values by the lowest amount and pushing the "<" button will multiply numerical values by 10.

Non numerical parameters are simply altered by using the ">" button to scroll through the options. Once the parameter has been set to the desired value, press the "E" button again to store this value.

Example:

To set the Target speed in PID control mode to 10,000 rpm

Select the "**Target**" screen using the "<" and ">" buttons.

Press the "E" button. The value should now change to "**0.0**" and a cursor should appear under the final 0.

Press the ">" button and the value will change to "**0.1**".

Press the "<" button five times. Each time the value should increase by a factor of 10.

The value should now read "**10000.0**".

Push the "E" button to save the value to memory, the cursor should now disappear.

Settings:

The following options appear in the menu.

Target (or PWM%): The target speed for PID control or the PWM percentage for open loop control

PID P: The PID Proportional Gain

PID I: The PID Integral Gain

PID D: The PID Derivative Gain

Max Sp: The Maximum speed of the motor

Min PWM: The Minimum allowable PWM Duty

Max PWM: The Maximum allowable PWM Duty

Accel: The Acceleration/Deceleration step for PWM ramping

Time: The time interval for PID error and time between PWM Acceleration steps

Division: The number of pulses per revolution for the photo interrupter

Analog: When "ON" Target speed or PWM% is controlled by the analog input

Auto Start: When "ON" the motor will begin turning immediately when power is supplied

Det Max: Turning this to "ON" will ramp the motor up to maximum speed for 10 time intervals and will determine the maximum speed of the motor

Run Motor: When "ON" the motor will be allowed to turn

Control: Select "PID" for closed loop PID speed control or "PWM" for open loop PWM control

Serial Settings:

Motor controller parameters can also be set using the serial interface of a PC and a straight through 9-pin serial cable. The supplied program can be used or a simple program can be written to alter the parameters. If you are going to write your own program, or alter the settings using a terminal program, the port settings should be 19200 baud, 8 Data Bits, No Parity and 1 Stop Bit.

Commands follow the structure

@0A CMND VAL CRLF

Where

A is the address 0 to 3, as set by the dip switches.

CMND is the Command as in the table below.

VAL is the numerical value for the parameter.

CRLF is Carriage Return Line Feed (Enter Key)

Example:

To set the Target speed of the motor controller with address 00 in PID mode to 10,000 rpm the following command would be used:

@00 SSPD 10000 (Enter)

The unit will respond with:

#00 SSPD 10000

Command	Description	Values
SSPD	Set Speed	>0
GPID	PID Proportional Gain	0 to 10
IPID	PID Integral Gain	0 to 10
DPID	PID Derivative Gain	0 to 10
MMAX	Motor Maximum Speed	>0
MINP	Minimum PWM Duty	0 to 100 (<=MAXP)
MAXP	Maximum PWM Duty	0 to 100 (>=MINP)
ACCN	PWM Acceleration	1 to 100
TIME	Time Interval	>0
DIVN	Input Division	1 to 255
ANLG	Analog input	0=OFF 1=ON
AUTO	Auto Start	0=OFF 1=ON
DMAX	Determine Maximum	1=Start
RUNM	Run Motor	0=OFF 1=ON
PIDC	Control	0=PWM 1=PID
STRT	Start Motor	No parameter
STOP	Stop Motor	No parameter

Notes:

The IRFZ44 Mosfet has a maximum current of 49A, voltage of 55V and an on resistance of 17.5mΩ. In reality the Mosfets will overheat and the PCB tracks will not handle this much current. As two are used it can be assumed that for a motor current of 20A, each Mosfet will be conducting approximately 10A. This means that each Mosfet will dissipate approximately 1.75W into the heatsink. The provided heatsink is rated at 5°C/W which will mean a temperature increase of approximately 17.5°C above ambient. A fan will help with the heat dissipation if the motor is going to draw this much current continuously.

The PWM signal controlling the Mosfets is available at a PCB pad labeled PWM to the right of the Mosfet labeled Q2. If you wish this PWM output can be used to drive a solid state relay or other higher current capable FET.

If you wish to just monitor the PWM output of the controller a 50% duty signal is available on an unlabeled PCB pad next to pin 15 of the ATmega168 IC. This can be used as a sync input for your oscilloscope and the PWM output can be monitored from the PWM pad.

Assembly:

Assembly of the DC Motor PID Speed Controller is relatively simple, however there are a few things to note.

Start with the lowest components first, the resistors and diodes and then work your way up to the taller components.

Note that R5, near the regulator is not 4.7kΩ as printed on the PCB but actually 240Ω, which is provided.

Leave the LCD, Potentiometer, Mosfets and large heatsink until last.

The small heatsink goes between the voltage regulator VR1 and the PCB, on the exposed metal area. You may wish to use some heat transfer compound between the heatsink and the PCB as well as between the heatsink and VR1. Pre-bend the regulators legs so that it will lie flat against the heatsink. Insert the screw from underneath the board, through the board, heatsink and voltage regulator. Tighten the nut and then solder the legs of the regulator.

For the Mosfets and large heatsink, loosely attach the two Mosfets to the heatsink using the screws and nuts and heat transfer compound then insert the Mosfets into the PCB. You will notice that the heatsink will not sit flush with the board but a few millimeters above, with its legs through the holes, approximately level with the underside of the board. Tighten the nuts holding the Mosfets to the heatsink and then solder the Mosfets and the heatsink to the PCB.

The Potentiometer can be mounted directly on the PCB in place of the 3-way terminal block, or the terminal block can be inserted to the PCB and the potentiometer can be mounted externally and wired to the terminals.

The LCD is mounted above the PCB on 25mm tapped spacers. To do this attach the spacers to the PCB using screws and then place the LCD module above and screw it into place. The two 14 way right angle IDC connectors need to be soldered on to the LCD and main PCB and these are connected using the 14 way sockets and ribbon cable.

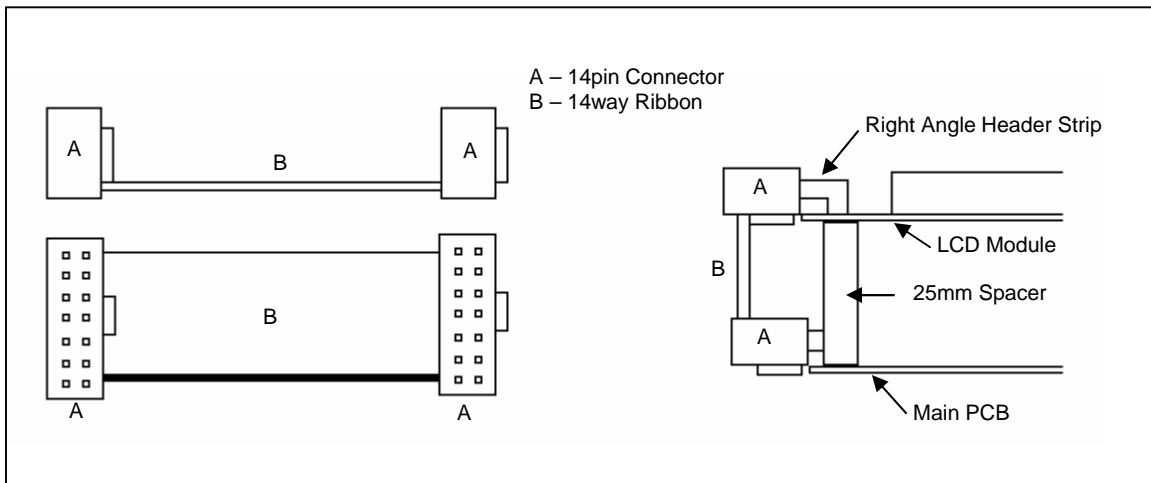

Parts List:

Part	Designator	Quantity
10R Resistor	R1,R2	2
1N4004 Diode	D3	1
1N4148 Diode	D1	1
18K Resistor	R3	1
10K Resistor	R4,R6-R8	4
1K Resistor	R9	1
240R Resistor	R5	1
22pF Cap Ceramic	C1,C2	2
0.1uF Cap 50V Monobloc	C3-C8	6
1uF Cap 63V Low ESR	C9-C12	4
470uF Cap 50V Low ESR	C13	1
DB9 Female Right Angle	K2	1
DB9 Male Right Angle	K3	1
2 way DIP switch	SW1	1
Max232	U3	1
74HC14	U2	1
7805 Regulator	VR1	1
8MHz Crystal	X1	1
14pin Socket		3
16pin Socket		1
Tact Switch	1,2,3	3
Large Heatsink		1
Small Heatsink		1
14 way IDC Ribbon		50mm
10mm M3 bolt		3
M3 Nut		3
6mm M3 Bolt		8
25mm Tapped M3 Spacer		4
10K 16mm Potentiometer		1
2way Terminal	T2-T5	4
3way Terminal	T6	1
14pin IDC cable socket		2
Right Angle Dual Header Strip 2x7pins	K4	2
Photo Interrupter		1
16x2 LCD		1
IRFZ44 MOSFET	Q1,Q2	2
FR302 Fast Recovery Diode	D2	1
ATMega168 Programmed	U1A,U1B	1
PCB		1

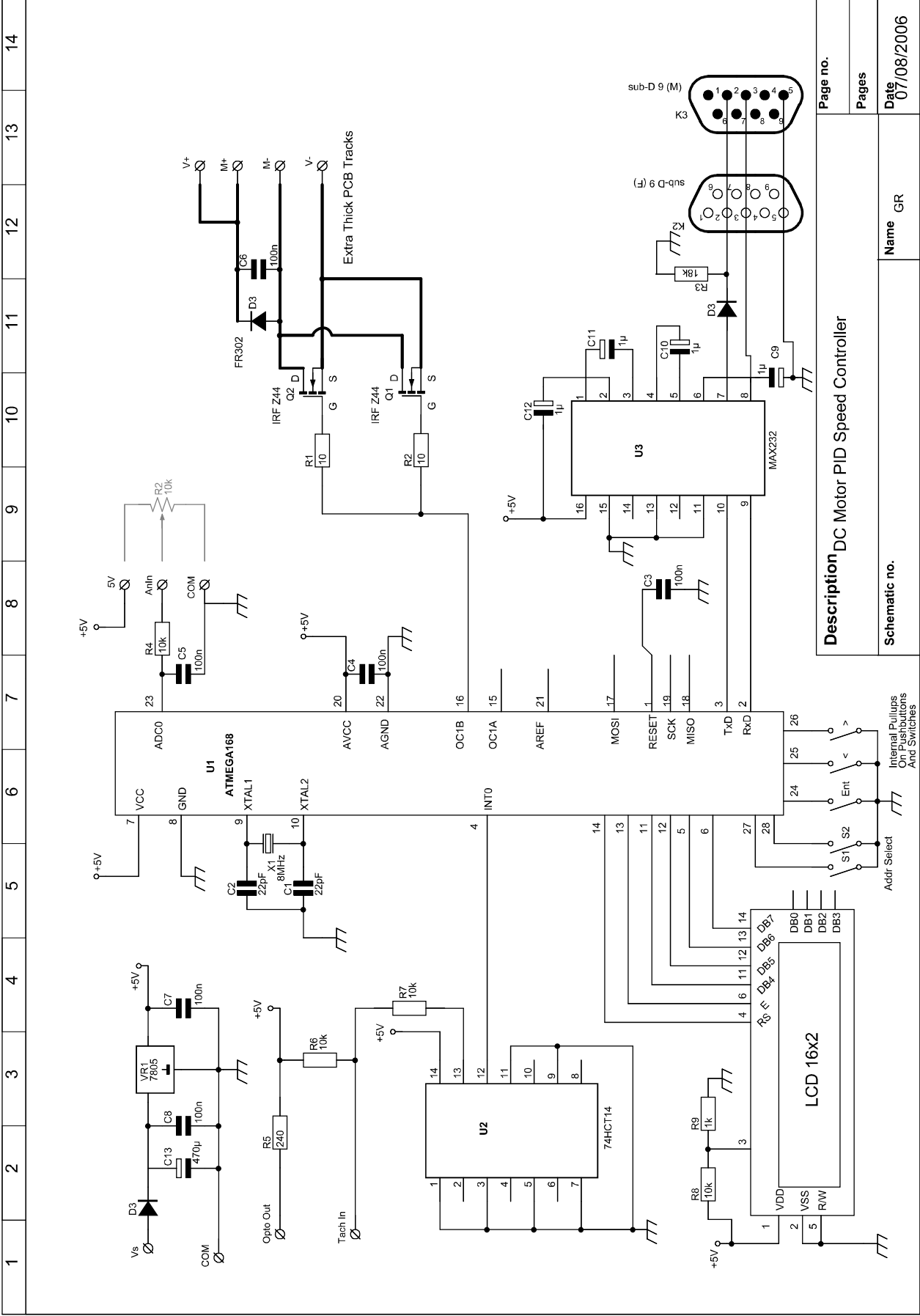

Description DC Motor PID Speed Controller	
Schematic no.	Name GR
Page no.	Pages
Date 07/08/2006	